

**Modular Converter Solutions
(MCS3)
User guide**

Purpose

This guide provides instructions to correctly install, commission and operate Powerware Modular Converter Solutions (MCS) power systems.

For Further Information and Technical Assistance

For further information and technical assistance, contact your Powerware DC product representative.

Record of Issue

Issue No	Issue Date	By	Change
00	27/06/2005	NS	First issue.

CONTENTS

1.0	GENERAL DESCRIPTION	4
1.1	MCS3 SUBRACK OVERVIEW	4
1.2	FEATURES	5
1.3	MODULAR CONVERTER MODULE	5
2.0	INSTALLATION.....	7
2.1	OUTPUT CONNECTION	7
2.2	INPUT CONNECTION	7
2.3	INSTALLING EXTERNAL ALARMS AND DIGITAL INPUT CABLING.....	8
2.4	OUTPUT VOLTAGE MONITORING (OPTIONAL).....	8
2.5	INPUT VOLTAGE MONITORING (OPTIONAL)	8
2.6	INSTALLATION OF MODULAR CONVERTER MODULE	9
2.7	INSTALLATION OF DIGITAL MONITOR	9
2.8	INSTALLING LOAD CIRCUITS	9
2.9	SYSTEM EARTH	10
3.0	SPECIFICATION	10
3.1	SUBRACK SPECIFICATION	10
3.1.1	<i>Mechanical</i>	10
3.1.2	<i>Electrical</i>	10
3.1.3	<i>Environmental</i>	10
3.2	CONVERTER SPECIFICATIONS	10
3.2.1	<i>48 - 12V Converter Specification</i>	10
3.2.2	<i>48 - 24V CONVERTER SPECIFICATION</i>	11
3.2.3	<i>24 - 12V CONVERTER SPECIFICATION</i>	12
3.2.3	<i>24 - 48V CONVERTER SPECIFICATION</i>	12

1.0 GENERAL DESCRIPTION

1.1 MCS3 SUBRACK OVERVIEW

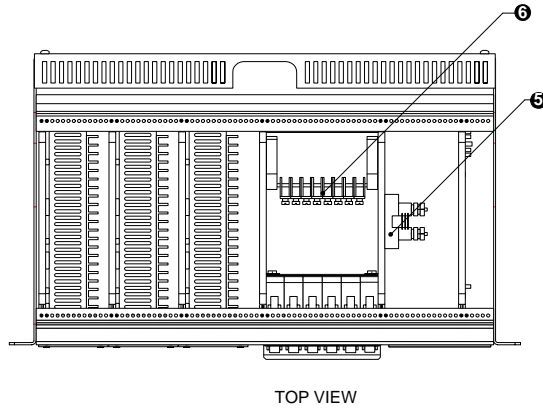

- ① Up to 3 DC-DC Converter Module
- ② Load Distribution panel
- ③ Digital Converter module
- ④ Up to 6 load miniature circuit breakers
- ⑤ Current shunt
- ⑥ Load common connection

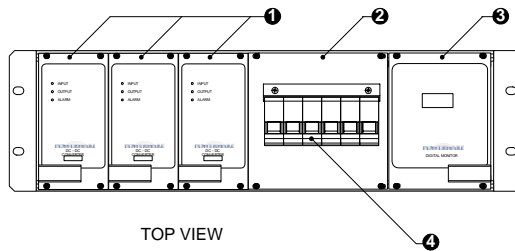

The Sub-rack frame is a 19" 3 RU Sub-rack frame that has been specifically designed to house the range of Modular Converter Modules and plug in accessories. The equipment can accommodate up to 3 x Modular Converter Modules and an optional Digital Monitor. It has been designed for ease of installation and maximum flexibility of configuration.

The Subrack frame has been designed in accordance with IEC 60297-3 and Din 41494 Part, 5 (482.6mm construction). It is manufactured using rack mounting sides and extruded aluminium mounting rails. It is complete with a backplane printed circuit board, which is fitted with high current copper bus bars for parallel connection of converter inputs and outputs. 6mm screw terminals are provided for the input and output connections. The backplane is also fitted with 3 x Din 41612H15 sockets for connection to the Modular Converter Modules and connectors for Digital Monitor.

MCS3 Distribution has a provision for connection of up to 6 off load circuits.

1.2 Features

- 19" 3 RU rack mount.
- Capable of housing up to 3x 300W Modular Converter Modules
- Optional Digital monitor
- Up to 3 voltage free alarm outputs
- Input and output copper bus bars connections
- Fully isolated input to output.
- Distribution Panel consists up to six (6) load miniature circuit breakers and common connection.
- Electronic circuit breaker trip sense.
- 2 x digital inputs

1.3 Modular Converter Module

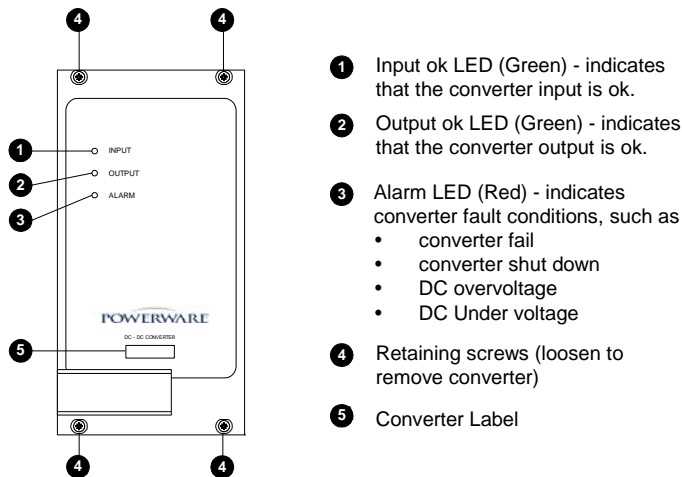

- 1 Input ok LED (Green) - indicates that the converter input is ok.
- 2 Output ok LED (Green) - indicates that the converter output is ok.
- 3 Alarm LED (Red) - indicates converter fault conditions, such as
 - converter fail
 - converter shut down
 - DC overvoltage
 - DC Under voltage
- 4 Retaining screws (loosen to remove converter)
- 5 Converter Label

Converters are paralleled in the MCS3 to provide the required power output. The converters have no forced current sharing. Converters share by voltage setting alone via low volt drop output diodes and are supplied preset at equal output voltages (refer table 1 below for default voltages).

The individual plug-in converter units are up to 300-watt output and can be supplied in a number of input and output voltage combinations as follows:

Input Voltage (Nom)	Output Voltage (Nom)	Output Current (at Nom Voltage)	Output Power (Max continuous)	Output Current at Default Voltage (refer note*)	Part No.
110Vdc	48Vdc	6A	300W	5.5A @ 54.4V	
	24Vdc	12A	300W	11.0A @ 28V	
	12Vdc	18A	250W	18.0A @ 14V	
48Vdc	48Vdc	6A	300W	5.5A @ 54.4V	
	24Vdc	12A	300W	11.0A @ 28V	115213
	12Vdc	18A	250W	18.0A @ 14V	112944
24Vdc	48Vdc	6A	300W	5.5A @ 54.4V	116832
	24Vdc	12A	300W	11.0A @ 28V	117157
	12Vdc	18A	250W	18.0A @ 14V	115209
12Vdc	48Vdc	6A	300W	5.5A @ 54.4V	
	24Vdc	12A	300W	11.0A @ 28V	
	12Vdc	12A	200W	14.3A @ 14V	

Table 1 – Modular converter module voltage reference

Note*: Default voltages shown above are before output diode. Actual voltage measured may be 0.4V lower, depending on the load current. For different output voltage settings consult the factory.

The converter output voltages are normally preset at default values of 54.4V, 28V and 14V respectively for 48V, 24V and 12V nominal systems. At these voltages the maximum output current ratings apply. These figures should be used for system sizing. At voltages less than nominal the rated current is the limiting condition (current limit). At voltages above nominal values the maximum power rating is the limiting condition. If a converter is overloaded, current limit will provide current protection and thermal shutdown will protect against excessive power demands.

2.0 INSTALLATION

MCS3 power system subrack comes pre-assembled with two rack mounting brackets. Fit the sub-rack into the 19" equipment rack and securely tighten 4 mounting screws (not supplied).

Provide sufficient airflow around the equipment to ensure ambient temperature does not exceed equipment specifications.

2.1 *Output connection*

With primary power isolated;

- Connect the output wiring to the output bus bar screw terminals using 6mm ring lugs (100A maximum per lug).
- Use the second screw terminal for output current exceeding 100A (200A total maximum current).
- Observe correct polarity
- Connect output positive to the top bus bar marked + VOUT and labelled + POSITIVE (Red) and securely tighten the terminal screws.
- Connect output negative to the 2nd bus bar from the top marked - VOUT and labelled - NEGATIVE (Black) and securely tighten the terminal screws.

2.2 *Input connection*

With primary power isolated;

- Connect the input wiring to the input bus bar screw terminals using 6mm ring lugs (100A maximum per lug).
- Use the second screw terminal for input current exceeding 100A (200A total maximum current).
- Observe correct polarity
- Connect input negative to the bottom bus bar marked - VIN and labelled - NEGATIVE (Black). Securely tighten the terminal screws.
- Connect input positive to the adjacent bus bar above (3rd bus bar from the top) marked + VIN and labelled + POSITIVE (Red). Securely tighten the terminal screws.

The order in which connections are made is unimportant.

2.3 Installing External Alarms and Digital Input Cabling

- Alarm relays and digital input terminations are located on the rear side of backplane of the MCS3 Subrack. Remove the socket and terminate the alarm wiring into the screw terminals (max cable size 2.5mm²) (max current 1A). Plug the alarm output socket back into the pin header (note that the socket can be fitted vertically or horizontally to the PCB in both polarities).

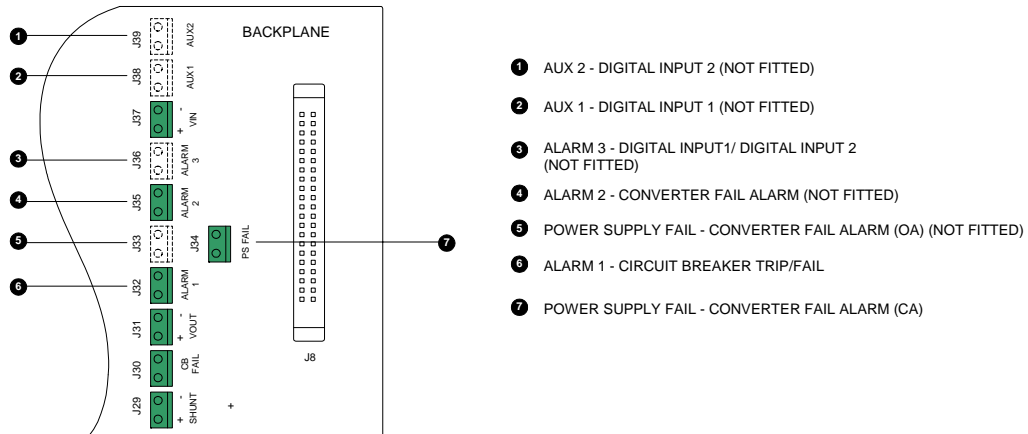

2.4 Output voltage monitoring (optional)

- Locate the (top) green 2-pin output voltage metering screw terminal socket located between the output negative bus bar and the output positive bus bar.
- Remove the socket and terminate the output voltage metering wiring into the screw terminals. (Max cable size 2.5mm²) (Max current 900mA).
- Plug the output voltage-metering socket back into the PCB mounted plug.

2.5 Input voltage monitoring (optional)

- Locate the (bottom) green 2 pin input voltage metering screw terminal socket located between the input negative bus bar and the input positive bus bar.
- Remove the socket and terminate the input voltage metering wiring into the screw terminals. (Max cable size 2.5mm²) (Max current 900mA).
- Plug the input voltage-metering socket back into the PCB mounted plug.

2.6 Installation of Modular Converter Module

- Align the PCB of the converter module with the card guides in the Subrack.
- Slide the Converter module into the Subrack until it engages into the backplane PCB.
- Engage the 4 converter module front panel screws into the Subrack rails and tighten.
- The converters are hot swappable and can be inserted or removed with the power connected provided that the remaining converters have the capacity to provide the load current with one converter removed.

2.7 Installation of Digital Monitor

- Align the PCB of the Digital Monitor with the card guides in the subrack.
- Slide the Digital monitor module into the subrack until it engages into the backplane PCB.
- Engage the 4 Digital Module front panel screws into the subrack rails and tighten.

2.8 Installing Load circuits

In a typical installation, at least 1RU of free space is required above the MCS to allow room for installing load cables and also allow enough ventilation to adequately cool the converters.

1. Terminate the common load cables at the top DC common bar.
2. Terminate the live load cables at the load MCBs.
3. Be careful to ensure the fuse fail detection wire is correctly terminated with the outgoing load live conductors.

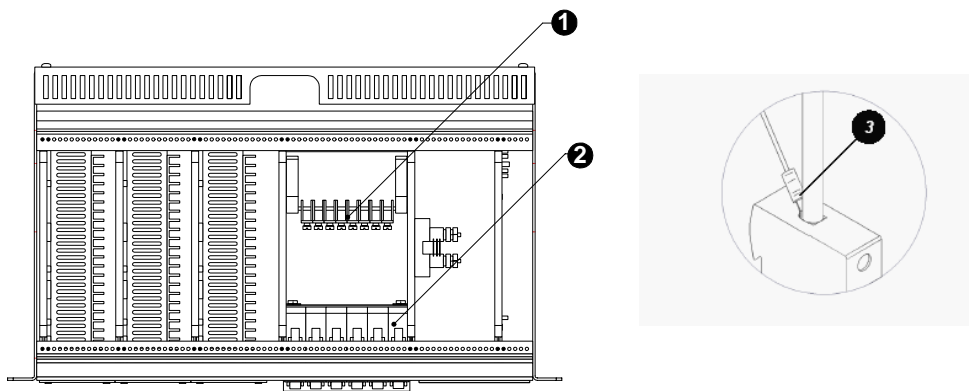

2.9 System Earth

The system voltage of MCS3 power system is referenced to either positive earth or negative earth. Refer to wiring drawing supplied with the system.

3.0 SPECIFICATION

3.1 Subrack Specification

3.11 Mechanical

Format	19" System in accordance with IEC 60297-3 Din 41494, part 5 (482.6mm Construction)
Height	3 Rack units (133mm)
Depth	260mm including terminals
Capacity	Up to 6 X converters + 1 X accessory module

3.12 Electrical

Converter Module connector	Din 41612H15 (30A per module)
Digital Monitor connector	Din 41612C64ac (1A max per pin)
Digital Interface connector	34-pin IDC header (1A max per pin)
Input terminals	M6 screw X2 (200A) (100A max per Screw)
Output terminals	M6 screw X2 (200A) (100A max per Screw)
Alarm connector	Camden CTB1301 style 2-way (2.5mm)
Input voltage metering connector	Phoenix MSTB style 2-way (2.5mm)
Output voltage metering connector	Phoenix MSTB style 2-way (2.5mm)

3.13 Environmental

Cooling	convection
Operating temperature	0 – 55degC
EMC	AS3548, CISPR 22 class B

3.2 CONVERTER SPECIFICATIONS

3.2.1 48 - 12V Converter Specification

ELECTRICAL	
Nominal input voltage	48V DC
Input voltage range	42-63V DC
Nominal output voltage	12V DC
Output voltage range	12-15V (adjustable via internal trimpot)
Default output voltage	14V
Output current	18A @ 14V or less / 250W max.above 14V
Efficiency	>80% (Typ 85%)
Line regulation	<+/-0.2%
Load regulation	<+/-0.5% (20% - 100% load)

Output ripple	<10mV RMS
Output noise	<+/-50mV
Current limit	set between 110-125% as required
Over voltage alarm/shutdown	shutdown set at approx 16V
Under voltage alarm	set at approx. 10.5V
Redundant operation	a diode with extremely low voltage drop is Fitted for parallel redundant option
Isolation	1 KV DC
Indicators	Input voltage, Output voltage, Fault

PROTECTION

Output over voltage	over voltage shutdown
Output short circuit	short circuit shutdown
Over temperature	over temperature shutdown

MECHANICAL

Construction (Or custom enclosure)	3RU 13 HP Eurocard or 19" rack mount 1RU
Connector rear (Or custom design)	Din 41612 H15 male or Screw Terminals on
Cooling	convection

ENVIRONMENTAL

EMC	AS3548, CISPR 22 class B
Operating temperature	0-55°C at rated power

3.2.2 48 - 24V CONVERTER SPECIFICATION**ELECTRICAL**

Nominal input voltage	48V DC
Input voltage range	42-63V DC
Nominal output voltage	24V DC
Output voltage range	23-30V (adjustable via internal trimpot)
Default output voltage	28V(before output diode)
Output current	12A @ 24V or less / 300W max. above 24V 11A @ 28V default setting
Efficiency	>80% (Typ 85%)
Line regulation	<+/-0.2%
Load regulation	<+/-0.5% (20% - 100% load)
Output ripple	<10mV RMS
Output noise	<+/-50mV
Current limit	set between 110-125% (adjustable)
Over voltage alarm/shutdown	shutdown set at approx 30V
Under voltage alarm	set at approx. 22V
Redundant operation	a diode with extremely low voltage drop is Fitted for parallel redundant option
Isolation	1 KV DC
Indicators	Input voltage, Output voltage, Fault

PROTECTION

Output over voltage	over voltage shutdown
Output short circuit	short circuit shutdown
Over temperature	over temperature Shutdown

MECHANICAL

Construction	3RU 13 HP Eurocard
Connector	Din 41612 H15 male or Screw Terminals on rear
Cooling	convection
ENVIRONMENTAL	
EMC	AS3548, CISPR 22 class B
Operating temperature	0-55°C at rated power

3.2.3 24 - 12V CONVERTER SPECIFICATION

ELECTRICAL

Nominal input voltage	24V DC
Input voltage range	21-31 V DC
Nominal output voltage	12V DC
Output voltage range	12-15V (adjustable via internal trimpot)
Default output voltage	14V(before output diode)
Output current	18A @ 14V or less / 250W max. above 14V
Efficiency	>80% (Typ 85%)
Line regulation	<+/-0.2%
Load regulation	<+/-0.5% (20% - 100% load)
Output ripple	<10mV RMS
Output noise	<+/-50mV
Current limit	set between 110-125% (adjustable)
Over voltage alarm/shutdown	shutdown set at approx 16V
Under voltage alarm	set at approx. 10.5V
Redundant operation	a diode with extremely low voltage drop is fitted for parallel redundant option
Isolation	1 KV DC
Indicators	Input voltage, Output voltage, Fault

PROTECTION

Output over voltage	over voltage shutdown
Output short circuit	short circuit shutdown
Over temperature	over temperature Shutdown

MECHANICAL

Construction	3RU 13 HP Eurocard
Connector	Din 41612 H15 male or Screw Terminals on rear
Cooling	convection

ENVIRONMENTAL

EMC	AS3548, CISPR 22 class B
Operating temperature	0-55°C at rated power

3.2.3 24 - 48V CONVERTER SPECIFICATION

ELECTRICAL

Nominal input voltage	24V DC
Input voltage range	20-30 V DC
Nominal output voltage	48V DC
Output voltage range	44-56V (adjustable via internal trimpot)

Default output voltage	54.4V(before output diode)
Output current	6A (300W max)
Efficiency	>80% (Typ 85%)
Line regulation	<+/-0.2%
Load regulation	<+/-0.5% (20% - 100% load)
Output ripple	<10mV RMS
Output noise	<+/-50mV
Current limit	set between 110-125% (adjustable)
Over voltage alarm/shutdown	shutdown set at approx 16V
Under voltage alarm	set at approx. 10.5V
Redundant operation	a diode with extremely low voltage drop is fitted for parallel redundant option
Isolation	1 KV DC
Indicators	Input voltage, Output voltage, Fault
PROTECTION	
Output over voltage	over voltage shutdown
Output short circuit	short circuit shutdown
Over temperature	over temperature Shutdown
MECHANICAL	
Construction	3RU 13 HP Eurocard
Connector	Din 41612 H15 male or Screw Terminals on rear
Cooling	convection
ENVIRONMENTAL	
EMC	AS3548, CISPR 22 class B
Operating temperature	0-55°C at rated power

DC-DC Converter part numbers are shown in the table in section 1 above.

~ END ~