

RE SERIES RACK INSTALLATION GUIDE

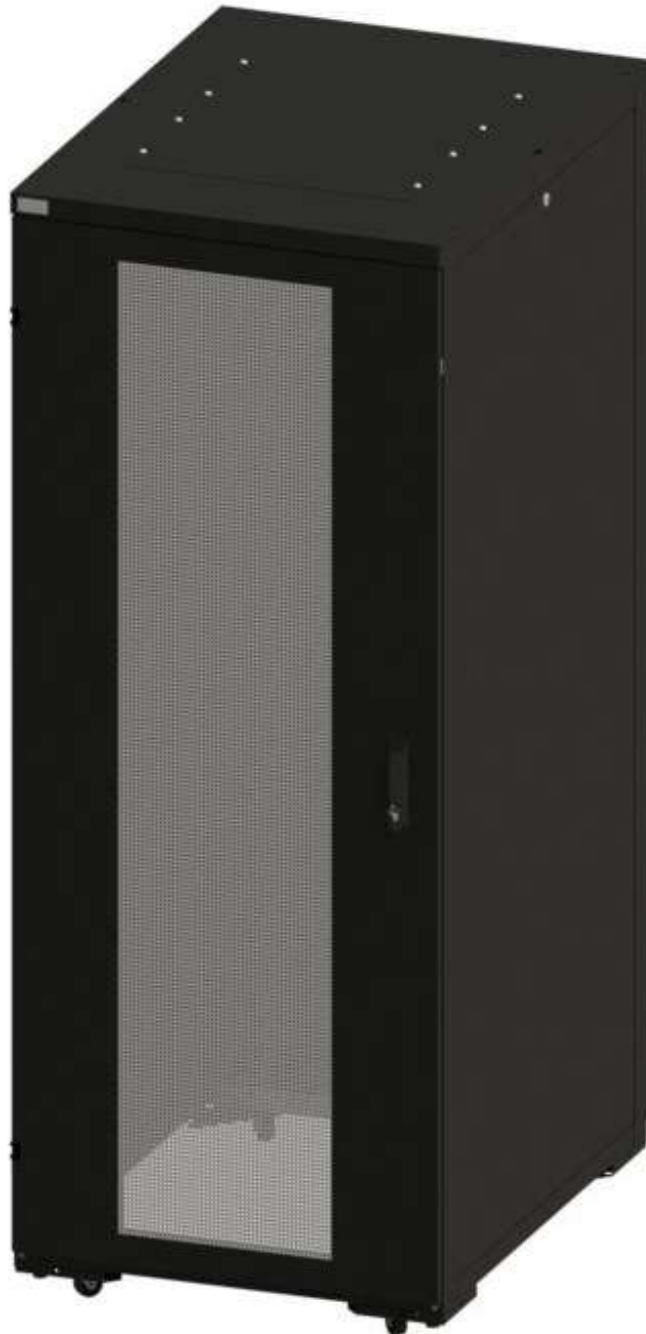

Powering Business Worldwide

RE Series Enclosure Installation Guide Issue 8

©2015 Eaton Corporation

All rights reserved

TABLE OF CONTENTS	SECTION
SAFETY WARNINGS	1
600 WIDE EXPLODED VIEW	2
800 WIDE EXPLODED VIEW	3
SWITCHING DOOR HANDING	4
STABILIZING	5
BAYING THE ENCLOSURE	6
SIDE PANEL	7
RACK MOUNT ADJUSTMENT	8
RACK EARTH BONDING	9

1. SAFETY WARNINGS



This manual contains important instructions that you should follow during installation and maintenance of the RE Series Enclosure. Please read all instructions before operating the equipment and save this manual for future reference.

1. **WARNING!** RE Series enclosure components can be very heavy. It is recommended that several people take part in the unpacking process. When lifting heavy components or electronic equipment, ensure that all safety regulations are observed.
2. **WARNING!** The RE Series enclosure is designed to support a Static Load of 800kg or a Dynamic Combined Load of 200kg. Dynamic Combined Load is the combined weight of the rack and installed equipment. The fitted casters are for transit only and are not intended to be used to move the rack when it is configured with equipment where the weight of the rack and equipment total over 200kg. The levelling feet (refer to Section 5 of this manual) must be in contact with the floor and supporting the rack before the rack is configured with equipment.
3. **WARNING!** The enclosure must be stabilized before installing any roll-out type accessory, component or electronic device. Failure to stabilize prior to installing equipment may cause the enclosure to tip over.
4. **WARNING!** First, load the heaviest electronic devices and accessories into the bottom of the enclosure to prevent the enclosure from becoming top-heavy.
5. **WARNING!** Never extend more than one roll-out type electronic device or accessory from a stabilized enclosure at a time. Do not sit, stand, or climb on any extended roll-out type electronic device or accessory. Never extend a roll-out type electronic device or accessory component from an enclosure rack that is supported by casters. Doing so may cause a stabilized enclosure rack to tip over.
6. **WARNING!** Ensure that the floor has a structural load capacity that will safely bear the weight of the RE series Enclosure and installed components.
7. **WARNING!** There must be an uninterruptible safety earth ground from the main power source to the Power Distribution Unit's (PDU) power cord set. Whenever it is likely that ground has been impaired, disconnect the PDU's power cord until the ground has been restored.
8. **WARNING!** High leakage current may be present. Grounding connection essential before connecting supply.
9. **WARNING!** Rack is intended to be used with equipment complying with IEC 60950. Use with non-compliant equipment may result in electrical hazard.
10. **WARNING!** A grounding kit is supplied with RE Series enclosures. The installer is responsible for grounding the enclosure to the building electrical system. Additional equipment can be electronically bonded to the rack's frame using additional grounding points

2. 600 WIDE EXPLODED VIEW

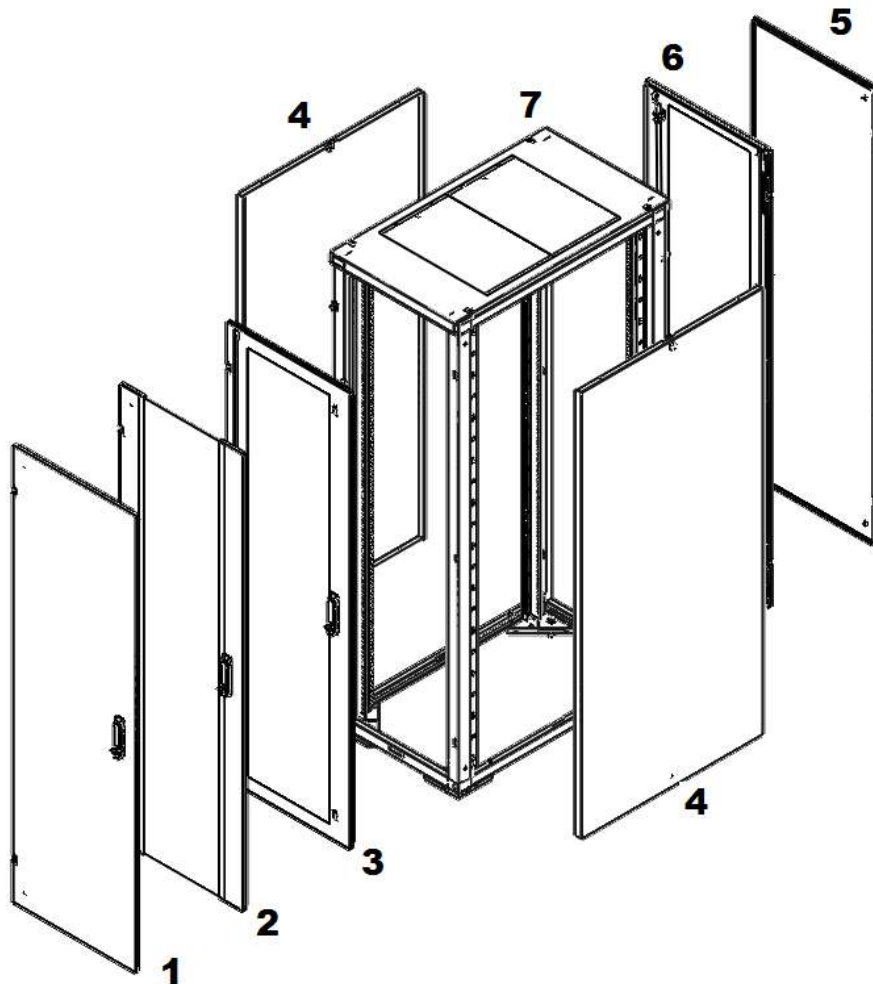

ITEM	DESCRIPTION
1	Steel door assy option
2	Glass door assy option
3	Vented door assy option
4	Side panel
5	Steel door supplied with vented front door
6	Vented door supplied with glass/steel front door
7	Enclosure frame

3. 800 WIDE EXPLODED VIEW

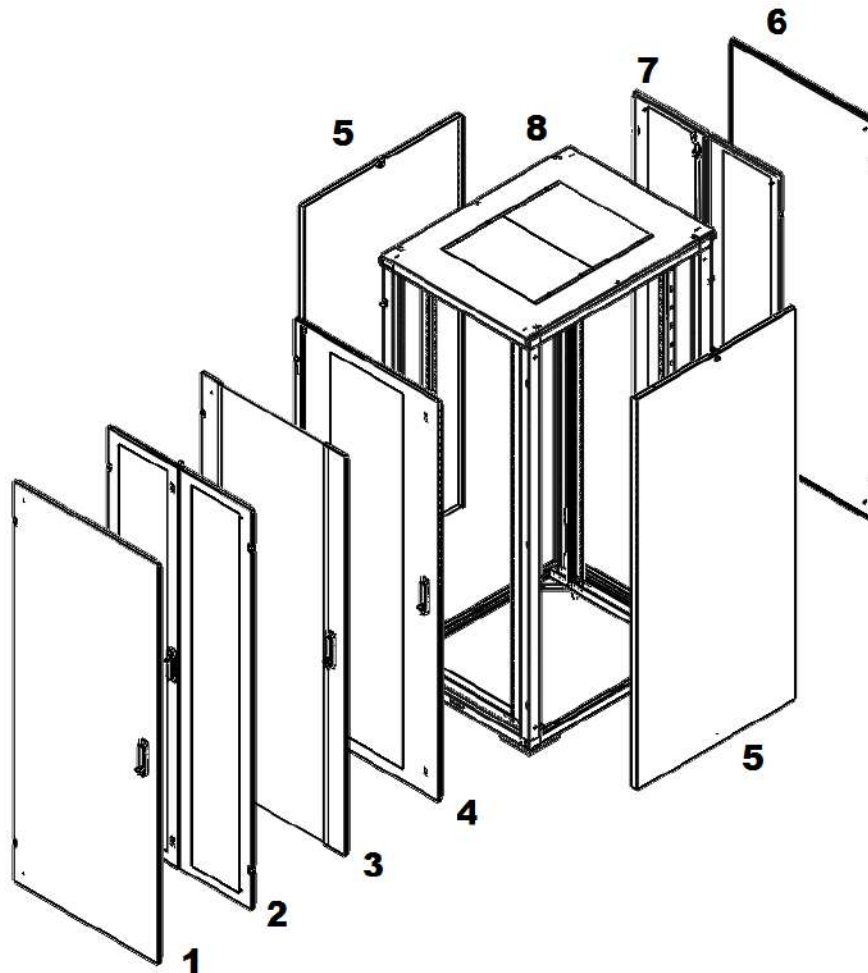

ITEM	DESCRIPTION
1	Steel door assy option
2	Double Vented door assy option
3	Glass door assy option
4	Vented door assy option
5	Side panel
6	Steel door supplied with vented/double front door
7	Double vented door supplied with glass/steel front door
8	Enclosure frame

4. SWITCHING DOOR HANDING

1. Remove the two hinge pins (Fig 1).
2. Remove the hinge section from the enclosure frame (Fig 2).
3. Re-install the two hinge sections to the opposite side of enclosure frame (Fig 2).
4. Rotate the door 180 degrees.
5. Re-install the two hinge pins (Fig 1).
6. Loosen the two screws which secure the locking rods (Fig 3).
7. Remove the two screws on the back of the door lock and fixing plate (Fig 3).

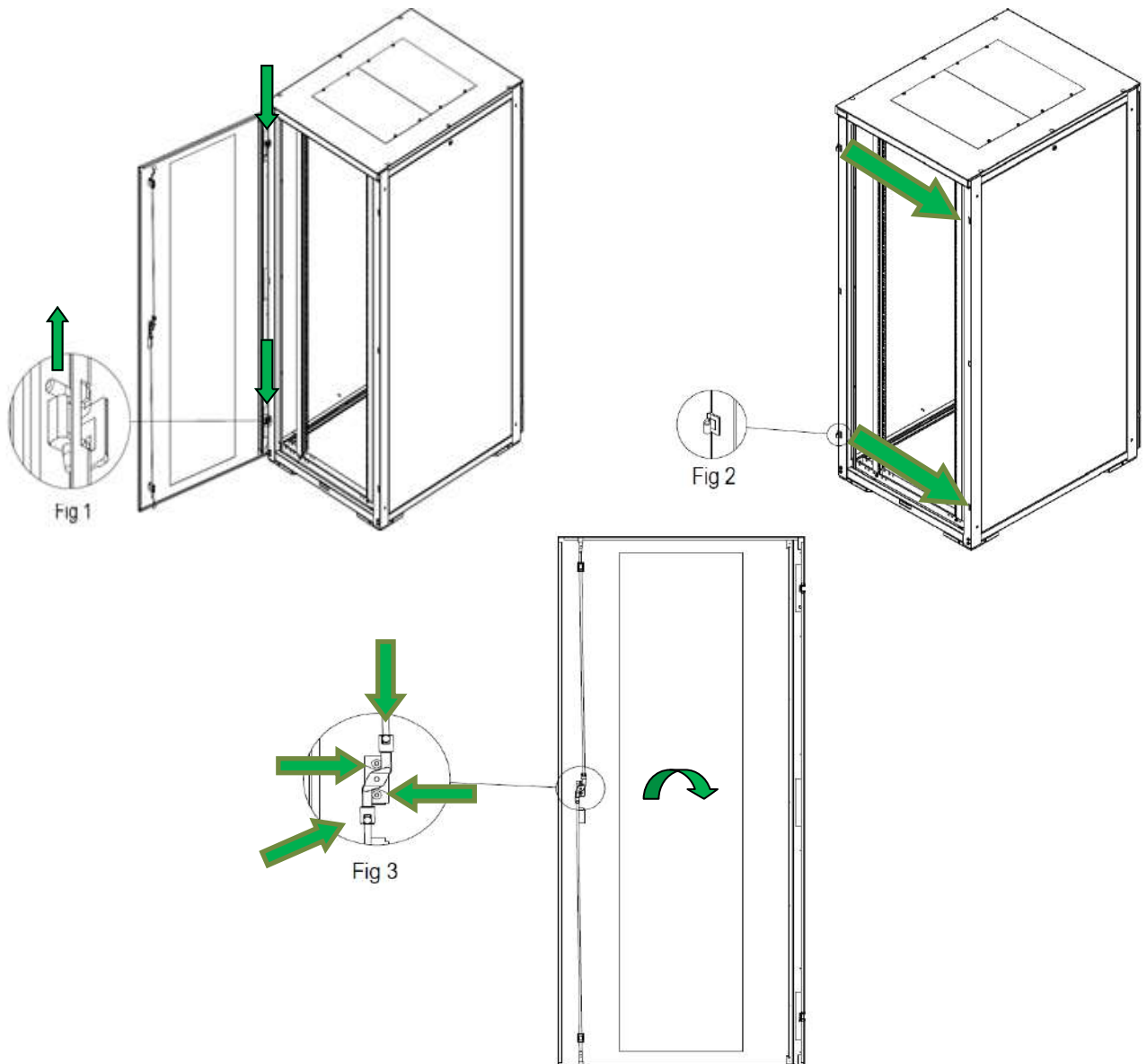

5. STABILIZING



Caution; Before the rack is configured with equipment (if the combined weight of the rack and equipment is over 200kg) THE FOLLOWING PROCEDURE MUST BE IMPLEMENTED AND THE RACK MUST REMAIN STATIC. If the rack is to be relocated then equipment MUST be removed before moving the rack.

Each enclosure is equipped with four leveling feet (Fig 1).

Use a 13 mm spanner to adjust the leveling feet. Ensure that each foot is in firm contact with the floor. Using a level, adjust the leveling feet as required to level the enclosure. For enclosures that have casters, extend the leveling feet so that the casters are approximately 3 mm off the floor.

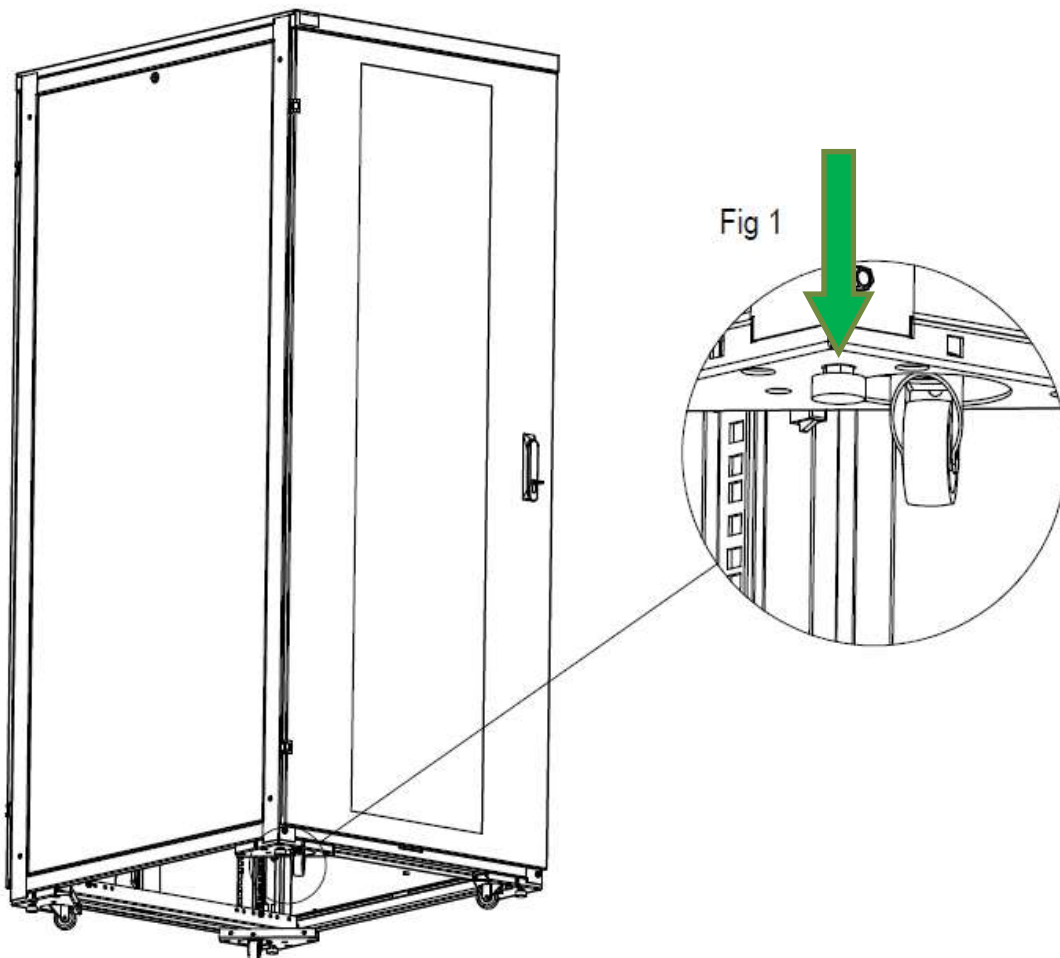

6. BAYING THE ENCLOSURE

1. Remove 4 blanking grommits per enclosure (Fig 1).
2. Position and level the adjacent enclosure frames. Ensure that the frames are precisely aligned both vertically and front-to-back.
3. Bolt the adjacent frames together with the 4 nuts, bolts, plain washers and serrated washers included in the baying kit, part number NRA BTK.

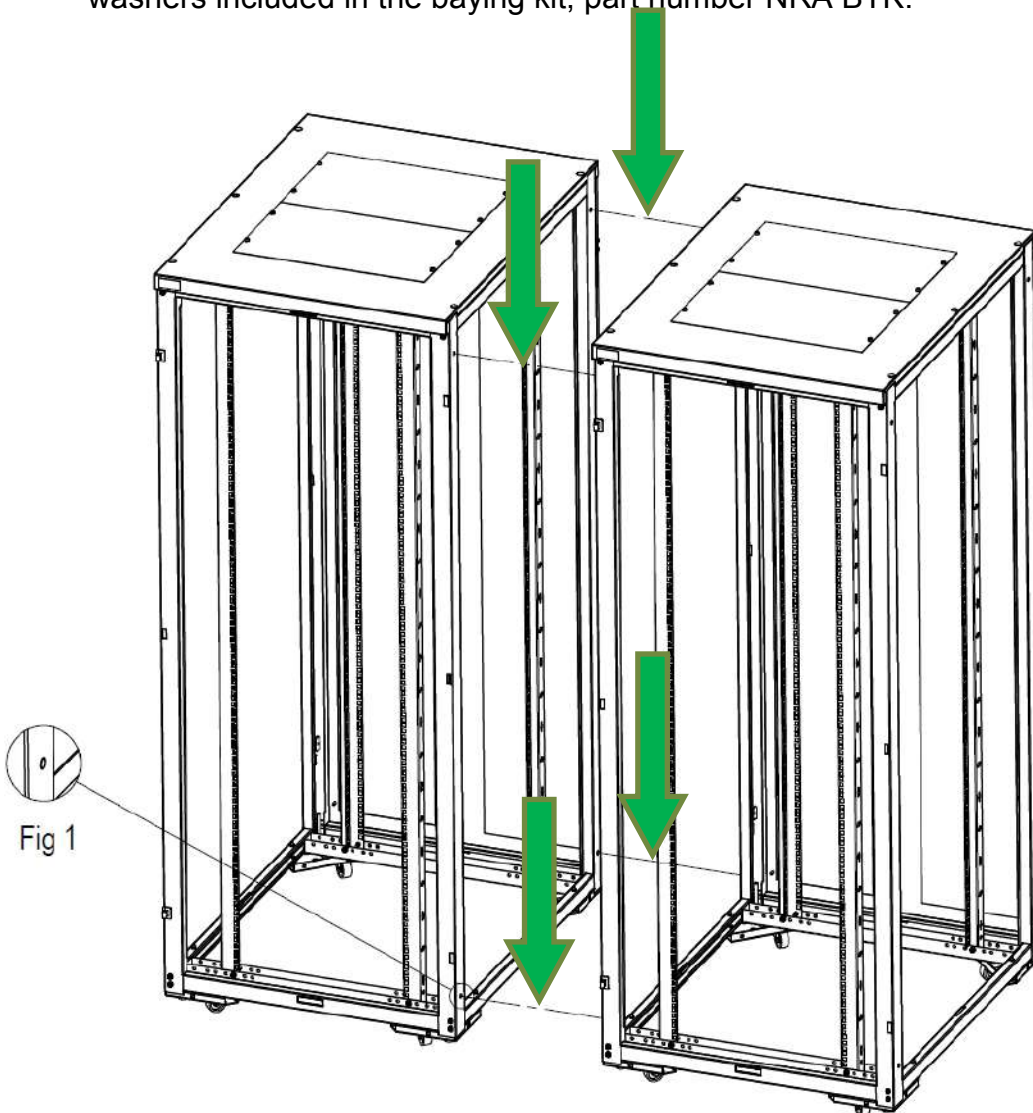

IMAGE WITH DOORS AND SIDE PANELS REMOVED

7. SIDE PANEL

Removal of side panel

1. Unlock the side panel with the key supplied (Fig 1).
2. Tilt the panel to clear the upper flange.
3. Lift the panel upwards to clear two locating pins (Fig 2).

Reinstall side panel

1. Align the two holes on the bottom of the side panel with the two pins on the enclosure frame. (Fig 2)
2. Then lower the side panel on to the pins.
3. Lock the side panel with the key supplied (Fig 1).

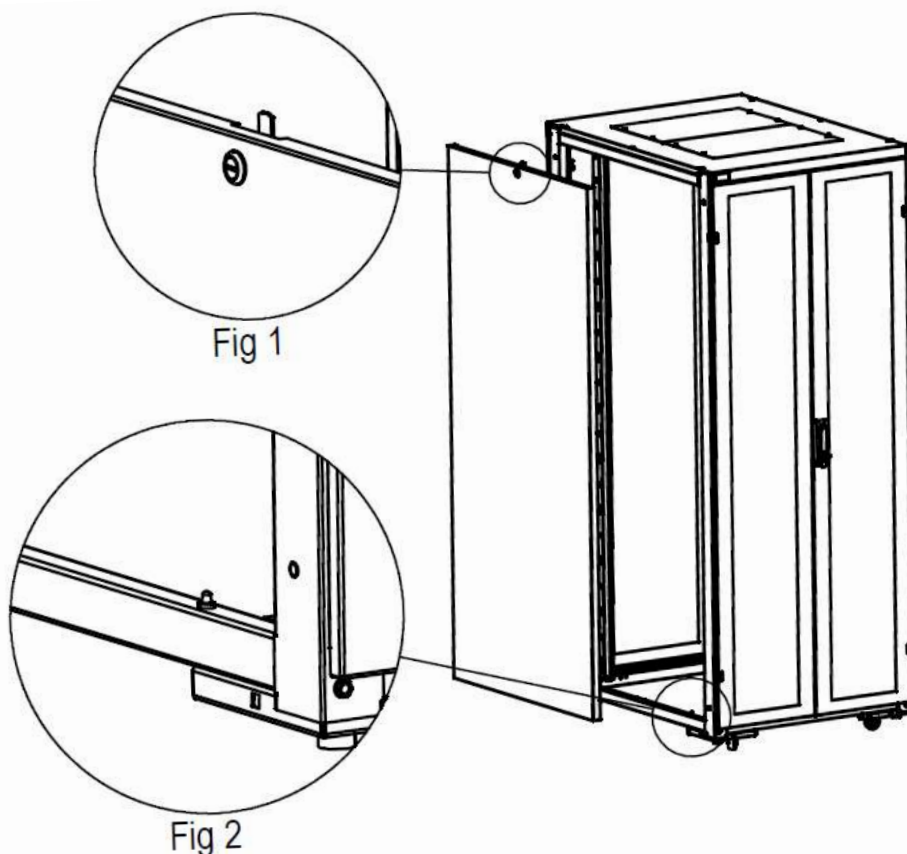

8. RACK MOUNT ADJUSTMENT

1. Loosen the four bolts using a 5mm Allen key, do not remove the bolt (Fig 1).
2. Slide rails to desired location.
3. Ensuring the rails are vertical, tighten the bolt with 5mm Allen key (Fig 1).

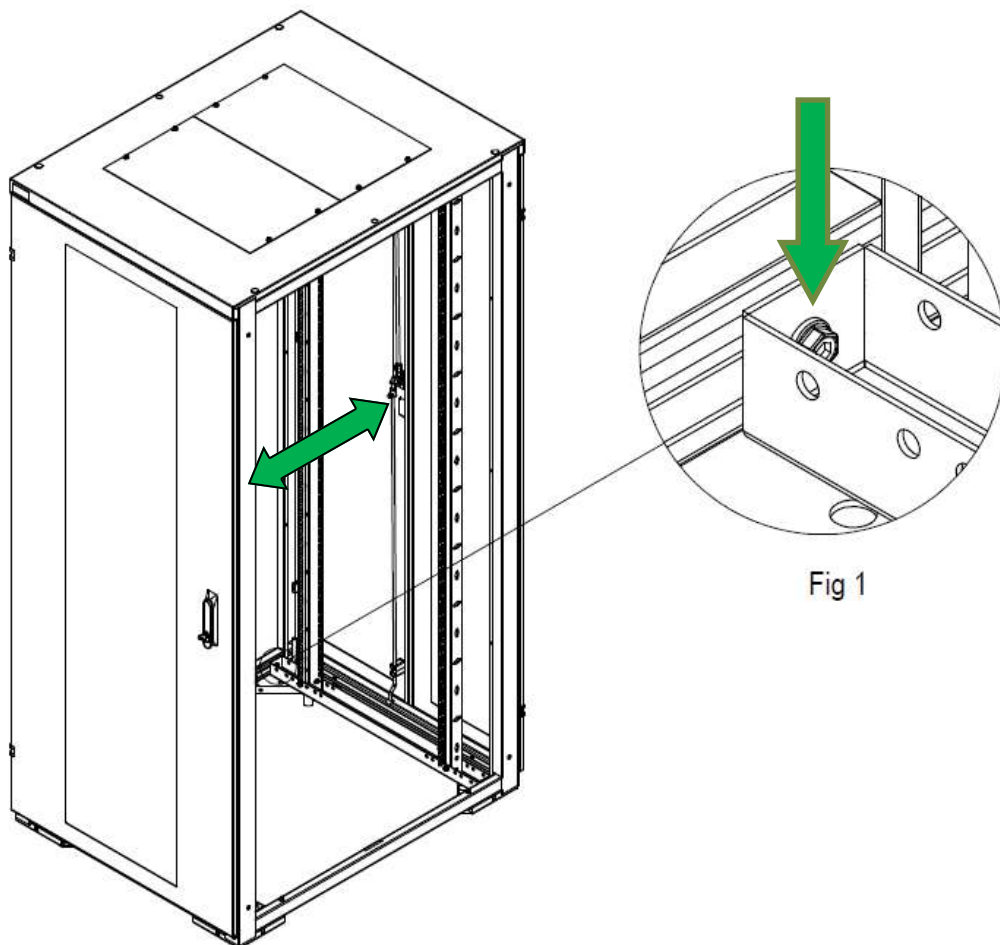

9. RACK EARTH BONDING

Earth Kit Components (note; not all components used in every application);

ITEM REF	IMAGE	DESCRIPTION	LENGTH	QUANTITY
1		M6 x 25mm Zinc Plated Setscrew	25mm	4
2		M6 Shake proof Washer		8
3		M6 x 12mm Setscrew (4mm Allen)	12mm	4
4		M6 Plain Washers		24
5		M6 Serrated Hexagonal Flange Nut		18
6		Earth Lead	500mm	2
7		Earth Lead	350mm	8

Tools required;

10mm spanner x 2

4mm Allen Key

Factory Fitted Component Earth

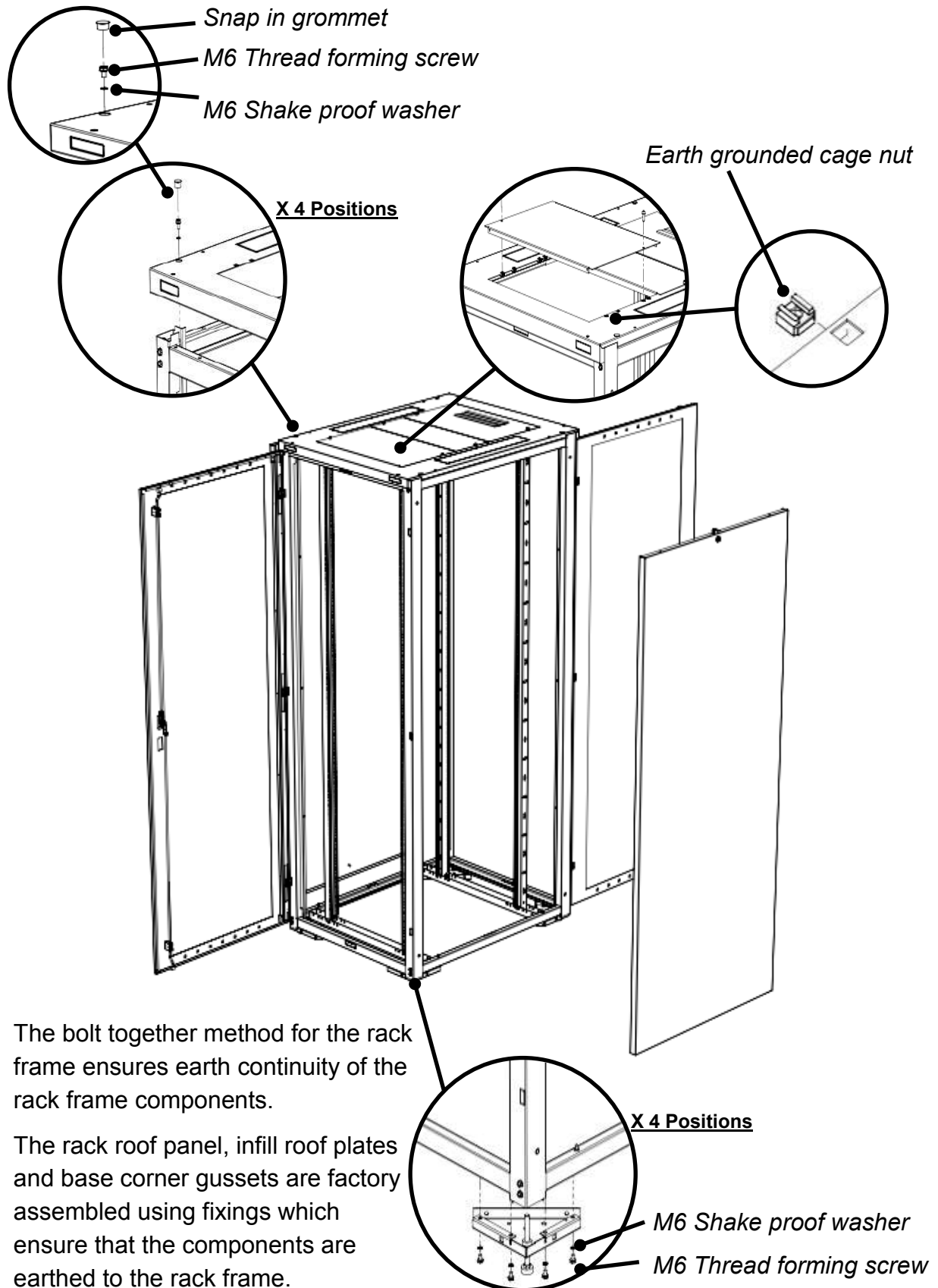

The bolt together method for the rack frame ensures earth continuity of the rack frame components.

The rack roof panel, infill roof plates and base corner gussets are factory assembled using fixings which ensure that the components are earthed to the rack frame.

Rack Earth Kit Fitting Instructions

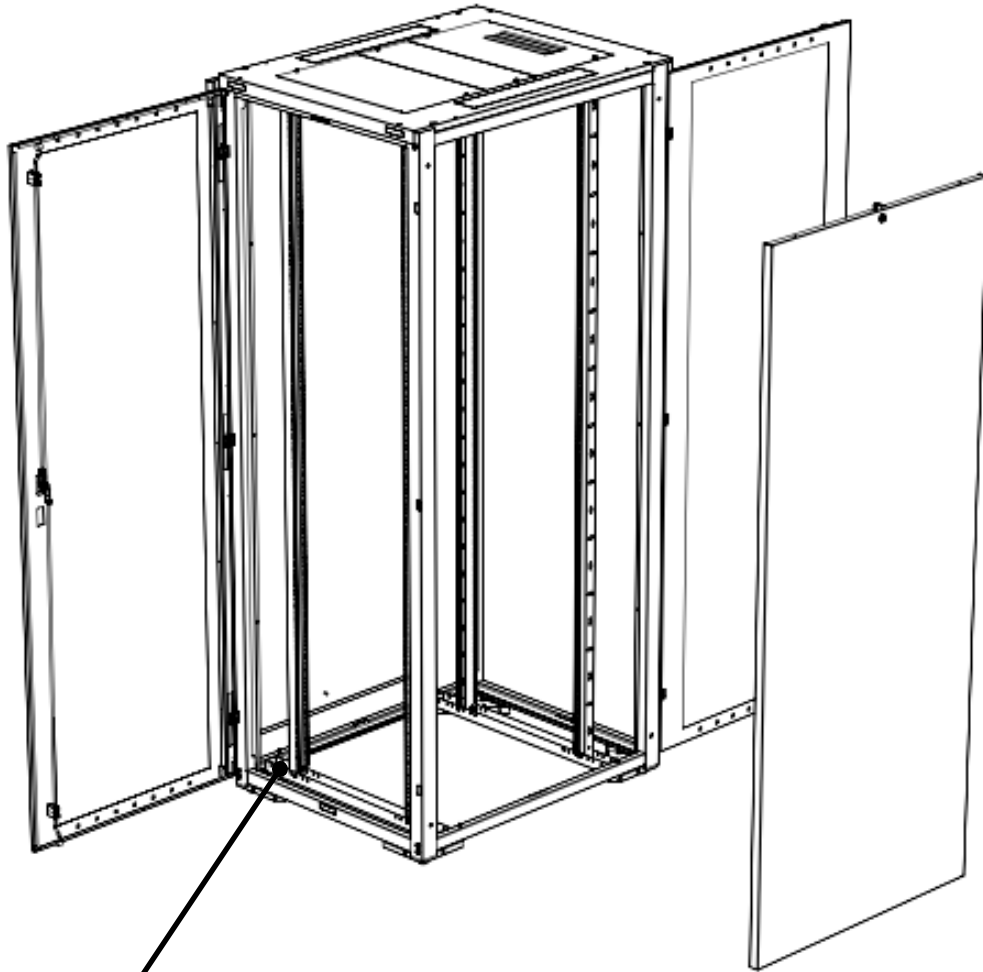

STEP 1 - MAIN RACK EARTH BONDING POINTS

Fit main rack earth bonding points to corner gussets adjacent to door hinge positions. If double doors are fitted then fit main earth points to both adjacent corner gussets.

Note - Main earthing points must be assembled so that the M6 Shake proof washer is fitted under the head of the M6 Setscrew as shown in Fig 1.0.

Tighten to 12Nm.

Repeat this step at the rear of the rack.

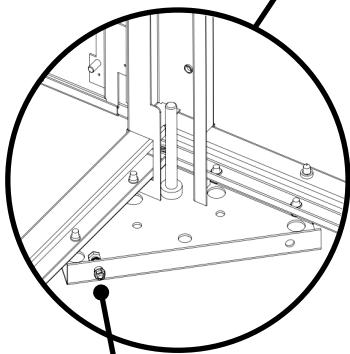
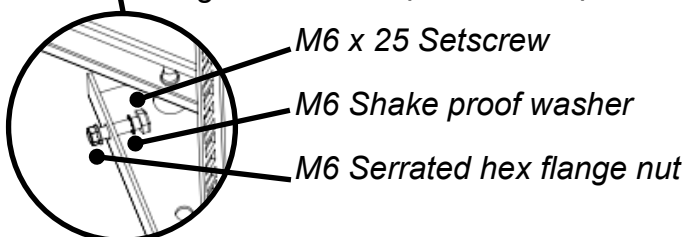

Fig 1.0



M6 x 25 Setscrew

M6 Shake proof washer

M6 Serrated hex flange nut

Installation Guide

STEP 2 - DOOR EARTH BONDING

Locate the door bottom earth stud (closest to the bottom hinge). Fit earth lead to door as shown in Fig 2.0. Tighten to 6Nm.

Repeat this step at the rear of the rack

Secure other end of earth lead as shown in Fig

M6 Plain washers (X2)

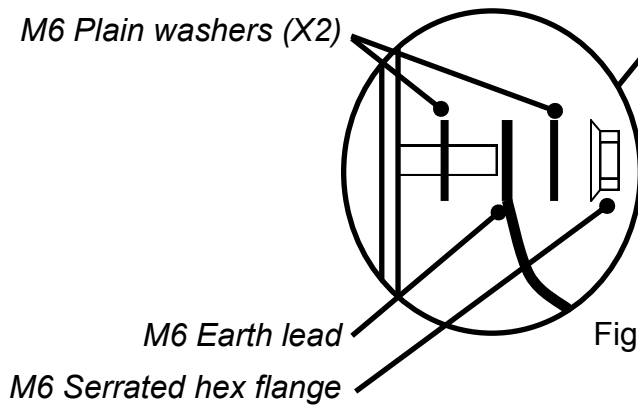

M6 Earth lead

M6 Serrated hex flange

Fig 2.0

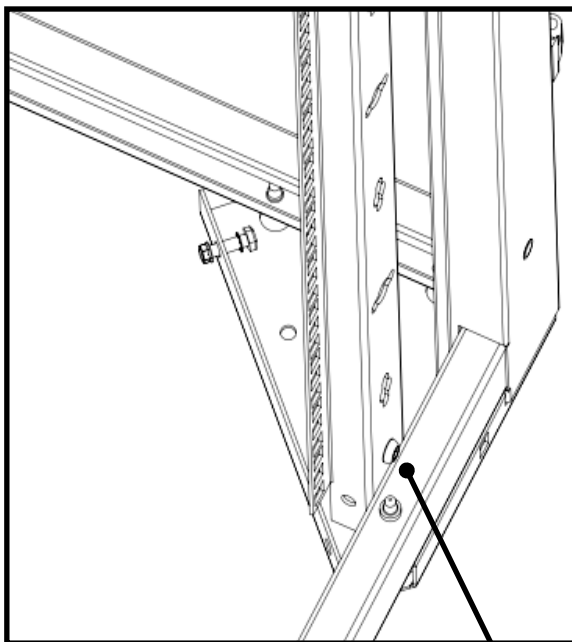
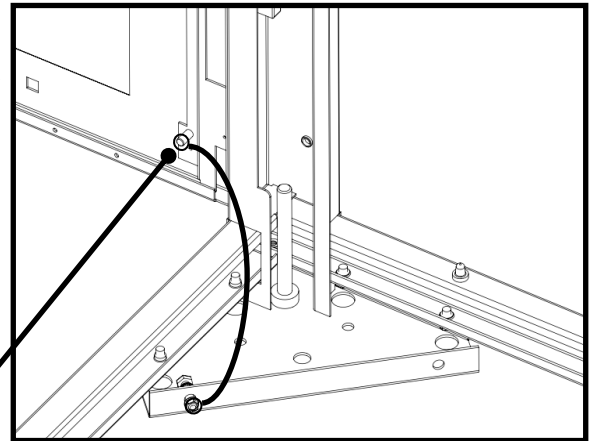

STEP 3 - 19-INCH RAIL EARTH BONDING

Remove the side panel to improve access.

Fit earth assembly as shown in Fig 3.0 and tighten assembly using a torque of

Fig 4.0

Use the same process for earth bonding the 19-inch mounting rails in an 800mm wide rack as shown in Fig

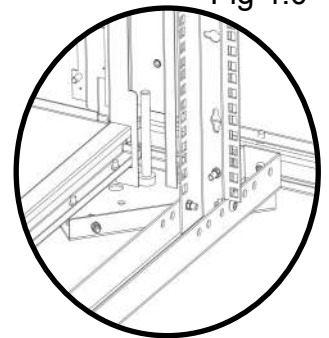

M6 Shake proof washer

M6 Serrated hex flange

M6 Earth lead (350mm) - connect to corner gusset

M6 X 12 Setscrew

M6 Plain washer

Fig 3.0

STEP 4 - SIDE PANEL EARTH BONDING

Connect the 500mm lead to the earth stud inside the side panel as shown in FIG 5.0.

Tighten to 6Nm.

Complete STEP 4 on opposite rack side connecting the RH side panel to the rear corner gusset.

M6 Plain washers (X2)

M6 Earth lead (500mm)

M6 Serrated hex flange nut

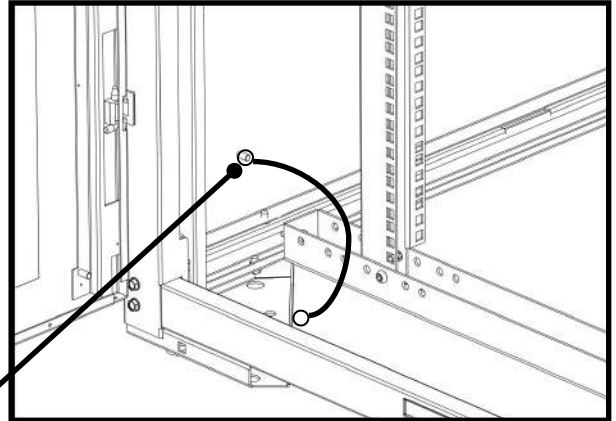
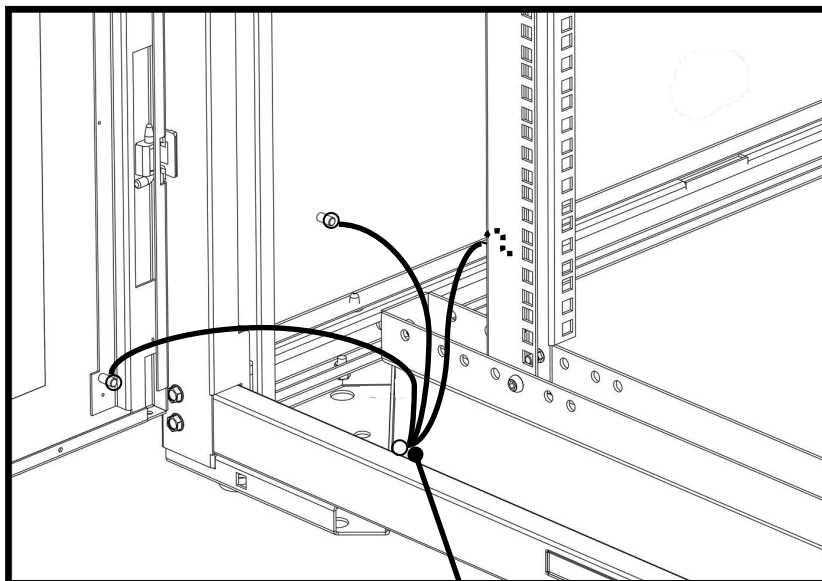

Fig 5.0



STEP 5 - EARTH BONDING TO MAIN EARTH POINTS

Taking the loose ends of the leads fitted in STEP 3 & STEP 4, connect the leads to the earth bonding point detailed in STEP 1 as shown in FIG 6.0.

Tighten to 12Nm.

Repeat STEP 5 at the rear of rack.

Fig 6.0

M6 Earth lead (350mm)

- To 19-inch rails

M6 Earth lead (500mm)

- To side panels

M6 Serrated hex flange nut

M6 Plain washers (X2)

M6 Earth lead

(350mm) - To doors

Installation Guide

Eaton is dedicated to ensuring that reliable, efficient and safe power is available when it's needed most. With unparalleled knowledge of electrical power management across industries, experts at Eaton deliver customised, integrated solutions to solve our customers' most critical challenges.

Our focus is on delivering the right solution for the application. But, decision makers demand more than just innovative products. They turn to Eaton for an unwavering commitment to personal support that makes customer success a top priority.

For more information, visit www.eaton.eu/electrical

Eaton Industries Manufacturing GmbH

Electrical Sector EMEA

Route de la Longeraie 7

1110 Morges, Switzerland

© Copyright 2012

All rights reserved.

Changes to the products, to the information contained in this document, and to prices are reserved; so are errors and omissions. Only order confirmations and technical documentation by Eaton is binding. Photos and pictures also do not warrant a specific layout or functionality. Their use in whatever form is subject to prior approval by Eaton. The same applies to Trademarks (especially Eaton, Moeller, and Cutler-Hammer). The Terms and Conditions of Eaton apply, as referenced on Eaton internet pages and Eaton order confirmations.

Eaton is a registered trademark of Eaton Corporation.

All other trademarks are the property of their respective owners.

